

## An IoT-Based Smart Utility Meter

A. R. Al-Ali, T. Landolsi, M. H. Hassan, M. Ezzeddine, M. Abdelsalam, M. Baseet

Computer Science and Engineering  
American University of Sharjah  
Sharjah, UAE  
e-mail: aali@aus.edu

**Abstract**—Empowered by the Internet of Things (IoT) technology, the consumption of electricity, water, and gas by appliances in residential units can be collected more frequently nowadays. However, these meters are still discrete and placed in different locations in apartments or houses. This paper proposes the design, development, and testing of an integrated IoT-based smart utility meter that monitors the consumption of electricity, water, and gas. The meter has a unique network address and can be programmed remotely to read the three utility consumptions at any desired frequency that can be set by the utility service providers. End consumers can access the meter through a personal computer or a mobile handset. Google Map markers are used to the display the status of the meter showing the consumption of each utility and whether the meter is connected or disconnected.

**Keywords;** *IoT; Smart meters; Raspberry Pi*

### I. INTRODUCTION

Obtaining meter records and generating invoices are essential procedures that utility companies perform on a regular basis. The current metering framework is based on multiple discrete meters that collect end users' consumption of electricity, water and gas. Each meter frequently measures a parameter and displays the records on an LCD screen attached to the meter. The time the meter updates the screen records depends on the meters' capabilities. The data collection of the metering system is accomplished by physical inspection of the individual meters that are scattered in different locations. For example, in residential zones electricity is measured by using electromechanical meters with rotating disks or with pointer dials to record the consumption of electricity. Each month, the utility sends its personnel to record those measurements manually, and then calculates each end user's bill through a central system. This traditional metering has a range of problems: It is labor intensive which is arising from the fact that each meter has to be inspected by the utility company's personnel, error prone since these readings must be done and reported to the central billing system manually. In addition, current metering systems do not allow homeowners to view their bill and how it correlates to their consumption until the end of billing cycle.

As the smart grid is evolving from the conceptual modeling phase to the implementation phase, smart meters are becoming one of the important devices that will enable the long-term vision of the smart grid. Collected data is transmitted to the utility center for processing and billing as well as monitoring the meters operations [1]. Current version of these meters are using single chip microcontrollers and several different wireless communication protocols such as power line carrier (PLC), wireless LANs e.g. Wi-Fi, cellular data e.g. GPRS, etc.[1, 2, 3]. Data analytic and visualization techniques are used to extract bill information and display consumption on a dashboard in a graphic format [4].

Some attempts have been reported for using smart water and gas meters but not many studies were discussed in the literature about electrical energy smart meters [5, 6]. For example, a smart meter that monitored water consumption utilizing the IoT concept and smart phone technologies is presented in [5].

A smart gas meter using M-bus gateway was implemented and presented in [7]. A micro-electro mechanical system (MEMS) thermal gas flow sensor using the IoT technology was reported in [8].

Form our literature survey, and to the best of our knowledge, there is no single integrated utility system that reads and monitors the three meters. Utilizing recent single chip microcontrollers that are equipped with sufficient number of general proposes input/output ports, large memory, high speed CPUs, built-in Ethernet ports and/ Wi-Fi access point, we were able to design a 3-in-1 smart utility system that integrates the metering functions for the consumption of electricity, water and gas.

This paper presents the design, prototyping, and testing of an IoT based smart utility meter. The meter reads the electricity, gas and water consumption simultaneously. It then reports the readings to the utility's cloud-based service for further processing. Home owners and utility personnel can access the meter via the Internet for monitoring and management purposes.

Our design uses a cost-effective Raspberry Pi-3 platform to perform automatic readings of the utilities consumption. It achieves data transmission to the utility backend system through wireless communication.

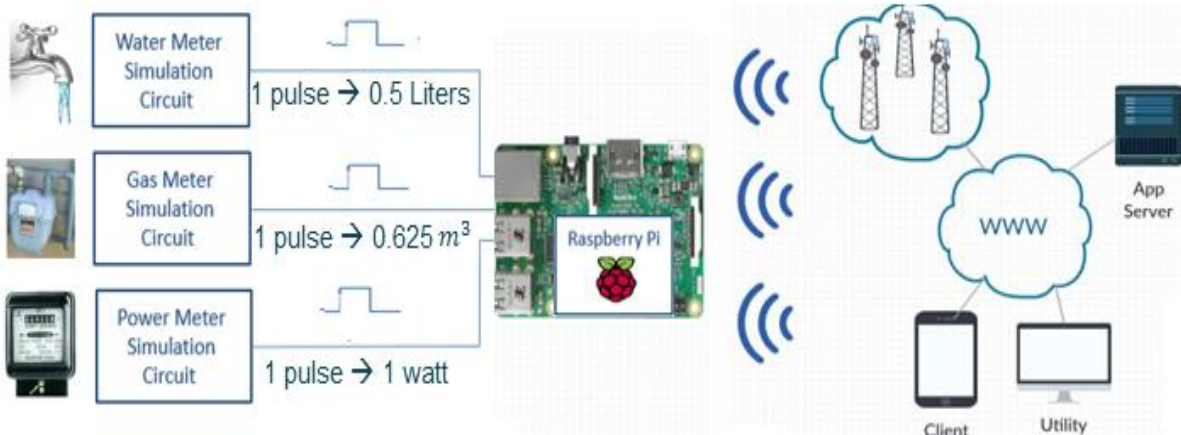

Figure 1 System hardware architecture.

## II. PROPOSED METER FUNCTIONAL AND NON-FUNCTIONAL REQUIREMENTS

To design a reliable meter, functional and non-functional requirements should be identified. Functional requirements (FR) are the specifications which identifies what the system should do. However, non-functional requirements (NFR) are specifications which state how the system performs a certain function.

### A. Functional requirements

The proposed system FR can be described as follows:

- The system allows utility authorizes members to login with their passwords.
- The system will save the utility member ID and displays their name at the top of the website.
- The name of the home owner will be the username and a random password will be generated from the utility website.
- Home owners will download a mobile application on any smart phone, and trace their consumption at any period of time.
- The system should provide for the authorized utility members a complete billing detail for any customer that includes; total bill and total consumption.
- The system allows the utility to generate statistics for previous consumptions for any customer.
- The system should display an embed Google maps that visualize the connectivity of any utility at any area in the utility website.
- The system will charge costumers according to their final consumption. If it exceeds a specific amount, the utility will charge them more on the extra consumption.
- The pricing schema will depends on the time of the consumption.

- The system allows utilities to manage meters' service flow and consumption.
- The utility service provider can connect or disconnect any of the utilities, if costumer fails to pay the bills, depending on the rules and regulations of the contract between the provider and the customer.
- The system provides an online payment system for the end users.

### B. Non-functional requirements

The NFR will describe how a system should behave and what limits there are on its functionality. The proposed systems NFR can be described as follows:

- Performance: the system should be capable of operating requests within seconds.
- Efficiency of use: the system accomplishes results quickly with accurately
- Security: each user must enter his information using a Hashed technique in saving the passwords. Data 512-bit encryption in transmission.
- Capacity: the system should be scalable and can handle large number of users at once.
- Manageability: the system provides the user with service to manage his consumption.

## III. PROPOSED SYSTEM HARDWARE ARCHITECTURE

To satisfy the above requirements, the proposed system hardware architecture has the following basic building blocks as shown in Figure 1:

- Power, water and gas meter circuits to read the consumptions. According to the datasheet of the utility meters. Each meter generates an output pulse that is equivalent 1 Watt, 0.5 litter of water and 0.625 m<sup>3</sup> gas [9].

- Computing element to register and consumptions and transmit it to the utility server. A Raspberry Pi 3 microcomputer is used. It has speed CPU, 1-MBytes of Flash Memory, 32-GBytes of SD RAM card, WiFi transceiver, 4-USB ports, 2-serail ports and 20+ general purpose digital inputs/output ports (GPIOs).
- High-end personal computer as utility application server.

#### IV. PROTOCOLS AND SOFTWARE ARCHITECTURE

To fulfill the software requirements and the system operations, two modules are developed namely; the data acquisition module (DAQ-M) and the utility module (UTL-M).

##### A. Data Acquisition Module (DAQ-M)

The DAQ-M is developed using Python programming language which is the favorite for the Raspberry Pi. It consists of a set of interrupts driven functions. Once a meter generates a pulse, the interrupt service routine is invoked and accumulates the consumption, frame and transmit it to the utility service for further actions. Operators can program the system the rate of transmission per 15-minutes, hour, day or month. The sequence diagram for the DAQ-M is shown in Figure 2.

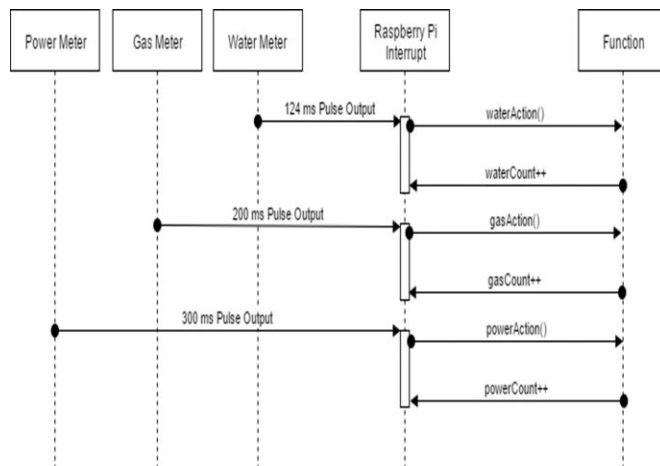

Figure 2. Proposed meter sequence diagram

##### B. Utility Module (UTL-M)

The UTL-M is developed to receive the consumptions from the DAQ-M, process the values according the tariff that is set by the utilities. The DAQ-M publishes the consumption values to a MQTT broker [iot.eclipse.org] with a specific topic. The UTL-M subscribes to the MQTT broker with the same topic and thus will be able to receive the consumptions values whenever they are updated. And android application is developed to enable both utility and consumers to access the consumption values on google map. Using the google markers, each meter rear-time status will be displayed with a color attribute. Green marker indicates at

the consumer supplies are connected, yellow is for marginal supplies and consumer needs service. Red marker means the service is discounted and consumer needs immediate attentions.

#### V. SYSTEM PROTOTYPE AND TESTING

With the support of utility meters suppliers, commercial electricity, water and gas meters prototype was developed, built and tested using three. Each meter was connected to a load. Consumption of electricity, water and gas are displayed in real-time on the meter LCD. The actual measured signal for each meter are used and connected to the proposed DAQ-M inputs. Processing the signals in the DAQ-M and UTL-M are done as described in section 4 and 5. Figure 3 shows the actual proposed system prototype. The automated results were displayed on the utility website and were compared with the real values shown on the LCD screens of the meters.

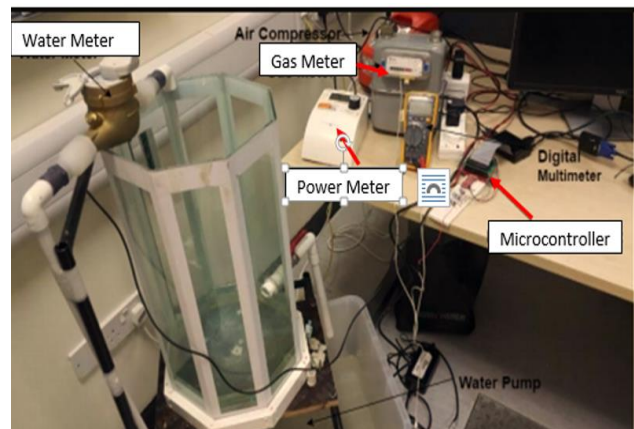

Figure 3. Proposed meter prototype.

The testing results of the proposed meters matched the readings of the actual meters with 97% accuracy. The error is due interrupt routines that handled the three pulses that are captured from the actual meters outputs. It is due to overlapping of the generated pulses. It is believed that this error can be handled if the interrupt priority configuration is utilized as well as the denouncing in the incoming pulse is handled with some software delay routine. It is recommended these sources of error must be solved in the update version of this proposed system. It is worth mentioning that the actual meter readings are not accurate due to humming reading error and manual data collection and processing.

Utilizing the Google maps and the developed GUI, screenshot were captured to check the meter status and actual read-time reading. Figure 4 shows a sample of the screenshots. Cost analysis is conducted. It was found that within couple years, the utility and consumers will save about 20-30% compared with existing metering techniques. This is due to consumer ability to monitor and control their consumptions and utility meet the supply-demand with variable tariff.

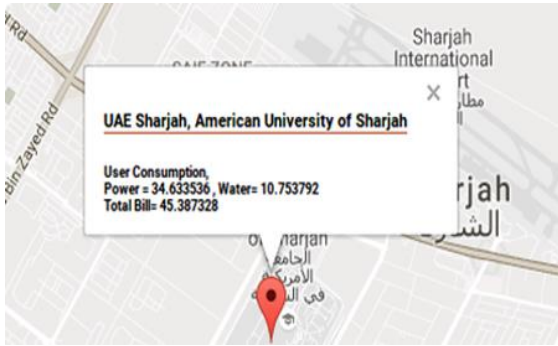

Figure 4. Screenshot of the mobile application using the GIS system.

## VI. CONCLUSION

An integrated 3-in-1 residential utility meter is designed utilizing the IoT technology. The meter measures electricity, water and gas consumptions and reports the readings to the utility server for further processing. Homeowners and utility operators can access the meter anytime from anywhere through Wi-Fi links. The status of the meter is displayed on a Google map with color attributes; green for in-service and red for out of service. A prototype was built and tested. The meter was within 97% accuracy when compared to the actual readings of the commercial meters that were connected to the same loads. In summary, the paper main contributions are the integration of the three utility meters in one, the accessibility to the proposed meter through mobile devices while displaying the meter status on a Google Map, and the utility can access the meter to change the tariff at the peak demand.

## ACKNOWLEDGMENT

The authors acknowledge the American University of Sharjah for supporting this research work. Special thanks to

Mr. David Tincin from a Dutco Group Company, Dubai for providing the commercial meters to build the prototype.

## REFERENCES

- [1] Y. Kabalci Survey on smart metering and smart grid communication 2017 *Renewable and Sustainable Energy Reviews* vol 57 (Elsevier) pp 302 -318.
- [2] Slavisa Aleksic, Vedad Mujan 2018 Exergy cost of information and communication equipment for smart metering and smart grids, *Sustainable Energy, Grids and Networks* vol 14 (Elsevier) pp 1-11.
- [3] Nitesh Rawat; Sonia Rana; Bhuvshesh Yadav; Neha Yadav 2016 A review paper on automatic energy meter reading system 3rd International Conference on Computing for Sustainable Global Development (IEEE) pp. 3254 – 3257.
- [4] Yi Wang; Qixin Chen; Tao Hong; Chongqing Kang 2018 Review of Smart Meter Data Analytics: Applications, Methodologies and Challenges *IEEE Transactions on Smart Grid* (IEEE Early Access) pp 1-1.
- [5] M.Suresh; U. Muthukumar; Jacob Chandapillai 2017 A novel smart water-meter based on IoT and smartphone app for city distribution management *IEEE International Symposium on Technologies for Smart Cities* (IEEE Region 10, India) pp 1-5.
- [6] Khoi A. Nguyen, Rodney A. Stewart, Hong Zhang, Oz Sahin, Nilmini Siriwardene Re-engineering traditional urban water management practices with smart metering and informatics *Environmental Modelling & Software*, 2018, vol 101, pp 256-267.
- [7] Živorad Mihajlović; Aleksandar Milankov; Lazar Živković; Miloš Tolić 2016 Implementation of wireless M-bus concentrator/gateway for remote reading of smart gas meters 24th *Telecommunications Forum* (IEEE) pp 1-4.
- [8] Shenglong Dong; Suohang Duan; Qing Yang; Jinlong Zhang; Guoguo Li; Renyi Tao 2017 MEMS-Based Smart Gas Metering for Internet of Things *IEEE Internet of Things Journal* vol 4, no. 5 pp 1296 - 1303.
- [9] Dutco Group Company, Dubai, United Arab Emirates, <http://www.dutco.com/home.aspx>